



**EDI 810**  
Invoice

ANSI Standard Version 4010

Revision: June 19,2000

For HSN Warehouse Fulfillment Only

**SEGMENT ISA - INTERCHANGE CONTROL HEADER**

**PURPOSE**

To start and identify an interchange of one or more functional groups and interchange-related control segments.

**EDI STANDARD SEGMENT**

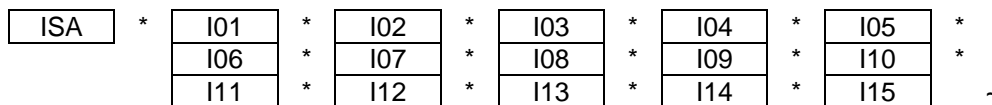

**HSN SUBSET OF EDI STANDARD SEGMENT**

Same as the EDI Standard Segment

ELEMENT NUMBER	ELEMENT NAME/DESCRIPTION	ELEMENT ATTRIBUTES	COMMENTS
ISA	<b>SEGMENT IDENTIFIER</b>		"ISA"
<b>I01 001</b>	<b>AUTHORIZATION INFORMATION QUALIFIER</b> Code to identify the type of information in the Authorization Information.	(M IS 2/2)	" 00 "
<b>I02 002</b>	<b>AUTHORIZATION INFORMATION</b> Information used for additional identification or authorization of the sender or the data in the interchange.	(M AN 10/10)	blank
<b>I03 003</b>	<b>SECURITY COMMUNICATION QUALIFIER</b> Code to identify the type of information in the Security Information.	(M ID 2/2)	" 00 "
<b>I04 004</b>	<b>SECURITY INFORMATION</b> This is used for identifying the security information about the sender of the data in the interchange.	(M AN 10/10)	blank

**NOTE REGARDING THE COMMENTS FIELD:** Actual values are contained within quotes

Home Shopping Network  
Transaction Set 810

01/17/10  
Page 3

---

<b>I05 005</b>	<b>INTERCHANGE ID QUALIFIER</b> Qualifier to designate the system/method of code structure used to designate the sender or receiver ID element being qualified.	(M ID 2/2)	Your interchange Qualifier Id
<b>I06 006</b>	<b>INTERCHANGE SENDER ID</b> Identification code published by the sender for other parties to use as the receiver ID to route data to them. The sender always codes this number in the sender ID element.	(M ID 15/15)	Your interchange Id
<b>I05 007</b>	<b>INTERCHANGE ID QUALIFIER</b> Qualifier to designate the system/method of code structure used to designate the sender or receiver ID element being qualified.	(M ID 2/2)	HSN interchange qualifier. " 12 "  Dropship Vendors Use " 01 "
<b>I07 008</b>	<b>INTERCHANGE RECEIVER ID</b> Identification code published by the sender for other parties to use as the receiver ID to route data to them.	(M ID 15/15)	HSN interchange Id.  "8135728585" – live "8135728585T" – test
<b>I08 009</b>	<b>INTERCHANGE DATE</b> Date of the interchange.	(M DT 8/8)	Interchange creation date (CCYYMMDD)
<b>I09 010</b>	<b>INTERCHANGE TIME</b> Time of the interchange	(M TM 4/4)	Interchange creation time. HHMM
<b>I10 011</b>	<b>INTERCHANGE CONTROL STANDARDS IDENTIFIER</b> Code to identify the agency responsible for the control standard used..	(M ID 1/1)	" U "
<b>I11 012</b>	<b>INTERCHANGE CONTROL VERSION NUMBER</b> Version number covers the interchange control segments and functional group control segments.	((M ID 5/5)	" 00401 "
<b>I12 013</b>	<b>INTERCHANGE CONTROL NUMBER</b> The number uniquely identifies the interchange data to the sender.	(M NO 9/9)	HSN sequential number

---

**NOTE REGARDING THE COMMENTS FIELD:** Actual values are contained within quotes

---

<b>I13 014</b>	<b>ACKNOWLEDGMENT REQUESTED</b> Code sent to request an interchange acknowledgment.	(M ID 1/1)	" 0 "
<b>I14 015</b>	<b>TEST INDICATOR</b> Code to indicate whether data enclosed by this interchange envelope is test or production.	(M ID 1/1)	" P " = production " T " = test
<b>I15 016</b>	<b>SUBELEMENT SEPARATOR</b>	(M AN 1/1)	" > "

**SEGMENT GS - FUNCTION GROUP HEADING**

**PURPOSE**

To indicate the beginning of a functional group and to provide control information.

**EDI STANDARD SEGMENT**

GS	*	479	*	142	*	124	*	29	*	30	*	28	*
		455	*	480		~							

**HSN SUBSET OF EDI STANDARD SEGMENT**

Same as the EDI Standard Segment.

ELEMENT NUMBER	ELEMENT NAME/DESCRIPTION	ELEMENT ATTRIBUTES	COMMENTS
GS	<b>SEGMENT IDENTIFIER</b>		"GS"
479 001	<b>FUNCTIONAL IDENTIFIER CODE</b> Code identifying a group of application related Transaction Sets.	(M ID 2/2)	" IN "
142 002	<b>APPLICATION SENDER'S CODE</b> Code identifying sending party.	(M AN 2/15)	Your interchange ID
124 003	<b>APPLICATION RECEIVER'S CODE</b> Code identifying receiving party.	(M AN 2/15)	HSN interchange ID "8135728585" – live "8135728585T" – test
29 004	<b>GROUP DATE</b> Date sender generated a group of transaction sets.	(M DT 8/8)	System date when group was created (CCYYMMDD).
30 005	<b>GROUP TIME</b> Time when the sender generated a functional group of transaction sets	(M TM 4/4)	Local time when group was generated (HHMM).
28 006	<b>GROUP CONTROL NUMBER</b> Assigned number originated and maintained by the sender.	(M ID 1/9)	HSN sequential number
455 007	<b>RESPONSIBLE AGENCY CODE.</b> Code used in conjunction with Data Element 480 to identify the issuer of the standard.	(M ID 1/2)	" X " for ASC X12.

---

<b>480</b>	<b>VERSION/RELEASE/INDUSTRY</b>	(M ID 1/12)	" 004010 "
<b>008</b>	<b>ID CODE</b>		version number

Version and release information of the EDI standard being used.

---

**SEGMENT ST - TRANSACTION SET HEADER**

**PURPOSE**

To indicate the start of a transaction set and to assign a control number.

**EDI STANDARD SEGMENT**

ST	*	143	*	329	~
----	---	-----	---	-----	---

**HSN SUBSET OF EDI STANDARD SEGMENT**

Same as EDI Standard Segment above.

<b>ELEMENT NUMBER</b>	<b>ELEMENT NAME/DESCRIPTION</b>	<b>ELEMENT ATTRIBUTES</b>	<b>COMMENTS</b>
<b>ST</b>	<b>SEGMENT IDENTIFIER</b>		"ST"
<b>143 001</b>	<b>TRANSACTION SET IDENTIFIER CODE</b> Code uniquely identifying a transaction set.	(M ID 3/3)	"810"
<b>329 002</b>	<b>TRANSACTION SET CONTROL NUMBER</b> Identifying control number assigned by the originator for a transaction set.	(M AN 4/9)	Unique control number identifying this transmission.

**SEGMENT BIG - BEGINNING SEGMENT FOR STANDARD INVOICES**

**PURPOSE**

To indicate the beginning of the invoice transaction set and transmit identifying numbers and dates.

**EDI STANDARD SEGMENT**

BIG	*	373	*	76	*	373	*	328	*
		328	*	327	*	640	~*		

**HSN SUBSET OF EDI STANDARD SEGMENT**

BIG	*	373	*	76	*	373	*	328	~
-----	---	-----	---	----	---	-----	---	-----	---

ELEMENT NUMBER	ELEMENT NAME/DESCRIPTION	ELEMENT ATTRIBUTES	COMMENTS
<b>BIG</b>	<b>SEGMENT IDENTIFIER</b>		"BIG"
<b>373</b>	<b>INVOICE DATE</b>	(M DT 8/8)	Vendor
<b>001</b>	Invoice Issue Date.		Date of invoice
<b>76</b>	<b>INVOICE NUMBER</b>	(M AN 1/22)	Vendor
<b>002</b>	Identifying number assigned by issuer		Invoice number
<b>373</b>	<b>PURCHASE ORDER DATE</b>	(M DT 8/8)	HSN Purchase Order Date
<b>003</b>	Date assigned by the purchaser to the Purchase Order.		(CCYYMMDD)
<b>324</b>	<b>PURCHASE ORDER NUMBER</b>	(M AN 1/22)	Purchase order number
<b>004</b>	Identifying number assigned by the order/purchaser.		(Length ≤ 10)
<b>328</b>	<b>RELEASE NUMBER</b>	(O AN 1/30)	**NOT USED**
<b>005</b>			
<b>327</b>	<b>CHANGE ORDER SEQUENCE</b>	(O AN 1/30)	**NOT USED**
<b>006</b>	<b>NUMBER</b>		



---

<b>640</b>	<b>TRANSACTION TYPE CODE</b>	(M ID 2/2)	DI = Debit Invoice To be used for invoice referencing only one PO
<b>007</b>			CI = Consolidated Invoice To be used for invoice referencing multiple PO's
			DU = Duplicate To be used for invoice previously sent.

**SEGMENT N1 – NAME**

*If drop ship vendor, omit ship-to N1 segment*

**PURPOSE**

To identify a party by type of organization, name and code.

**EDI STANDARD SEGMENT**

N1 \* 98 \* 93 \* 66 \* 67 ~

**HSN SUBSET OF EDI STANDARD SEGMENT**

N1 \* 98 \* 93 \* 66 \* 67 ~

ELEMENT NUMBER	ELEMENT NAME/DESCRIPTION	ELEMENT ATTRIBUTES	COMMENTS
N1	SEGMENT IDENTIFIER		" N1 "
98 001	ENTITY IDENTIFIER CODE Code identifying an organizational entity, a physical location, or an individual.	(M ID 2/2)	" ST"
93 002	NAME Free-form name.	(M AN 1/60)	<b>HSN Mandatory</b> HSN Warehouse " Salem "
	IDENTIFICATION CODE QUALIFIER Code designating the system/method of code structure used for Identification Code (67).	(M ID 2/2)	<b>HSN Mandatory</b> " Waterloo "
67 004	IDENTIFICATION CODE Code identifying a party or other code.	(M AN 2/80)	<b>HSN Mandatory</b> Salem = "97" Waterloo = "98" Showroom = "01" Jewelry = "99"

**SEGMENT N1 - NAME**

**PURPOSE**

To identify a party by type of organization, name and code.

**EDI STANDARD SEGMENT**

N1
----

 \* 

98
----

 \* 

93
----

 \* 

66
----

 \* 

67
----

 ~

**HSN SUBSET OF EDI STANDARD SEGMENT**

N1
----

 \* 

98
----

 \* 

93
----

 \* 

66
----

 \* 

67
----

 ~

ELEMENT NUMBER	ELEMENT NAME/DESCRIPTION	ELEMENT ATTRIBUTES	COMMENTS
N1	SEGMENT IDENTIFIER		" N1 "
98 001	ENTITY IDENTIFIER CODE Code identifying an organizational entity, a physical location, or an individual.	(M ID 2/3)	" SU "
93 002	NAME Free-form name.	(C AN 1/60)	<b>HSN Mandatory</b> Vendor Company Name
66 003	IDENTIFICATION CODE QUALIFIER Code designating the system/method of code structure used for Identification Code (67).	(C ID 2/2)	<b>HSN Mandatory</b> " 92 "
67 004	IDENTIFICATION CODE Code identifying a party or other code.	(M AN 2/80)	<b>HSN Mandatory</b> HSN Internal Vendor Number

**SEGMENT ITD – TERMS OF SALE**

**PURPOSE**

Terms of Sale/Deferred Terms of Sale.

**EDI STANDARD SEGMENT**

ITD	*	336	*	333	*	338	*	370	*	351	*	446	*
		386	*	362	*	388	*	389	*	342	*	352	*
		765	*	107	*	954	~						

**HSN SUBSET OF EDI STANDARD SEGMENT**

ITD	*	336	*	333	*	338	*	370	*	*	446	*	386	*
		362	~											

ELEMENT NUMBER	ELEMENT NAME/DESCRIPTION	ELEMENT ATTRIBUTES	COMMENTS
ITD	SEGMENT IDENTIFIER		“ ITD “
336 001	TERMS TYPE CODE Code identifying type of payment terms.	(M ID 2/2)	“ ZZ “
333 002	TERMS BASIS DATE CODE Code identifying the beginning of the terms period (1=shipdate, 2=delivery date, 3=invoice date)	(M ID 1 /2)	“ 2 “
338 003	TERMS DISCOUNT PERCENT Terms discount percentage	(O R 1/6)	Discount rate (i.e 2.5% =2.5)
370 004	TERMS DISCOUNT DUE DATE Date payment is due if discount is to be earned	(C DT 8/8)	Date payment is due in order to receive discount (ccyymmdd)
351 005	TERMS DISCOUNT DAYS DUE Number of days in the terms discount period by which payment is due if terms discount is earned.	(C N0 1/3)	Number of Days
446 006	TERMS NET DUE DATE Date when total invoice amount becomes due.	(O DT 8/8)	Date payment is due (ccyymmdd)
386 007	TERMS NET DAYS Number of days until total invoice amount is due.	(O N0 1/3)	Number of days until payment is due

**NOTE REGARDING THE COMMENTS FIELD:** Actual values are contained within quotes

Home Shopping Network  
Transaction Set 810

01/17/10  
Page 13

---

<b>362</b>	<b>TERMS DISCOUNT AMOUNT</b>	(O N2 1/10)	Dollar Amount Discounted
<b>008</b>	Total Amount Discounted if paid within Terms Discount Days Due		
<b>388</b>	<b>TERMS DEFERRED DUE DATE</b>	(O DT 8/8)	"NOT USED"
<b>009</b>			
<b>389</b>	<b>DEFERRED AMOUNT DUE</b>	(C N2 1/10)	"NOT USED"
<b>010</b>			
<b>342</b>	<b>PERCENT OF INVOICE</b>	(C R 1/5)	"NOT USED"
<b>011</b>	<b>PAYABLE</b>		
<b>352</b>	<b>DESCRIPTION</b>	(O AN 1/80)	"NOT USED"
<b>012</b>			
<b>765</b>	<b>DAY OF MONTH</b>	(C N0 1/2)	"NOT USED"
<b>013</b>			
<b>107</b>	<b>PAYMENT METHOD CODE</b>	(O ID 1/1)	"NOT USED"
<b>014</b>			
<b>954</b>	<b>PERCENT</b>	(O R 1/10)	"NOT USED"
<b>015</b>			

---

**NOTE REGARDING THE COMMENTS FIELD:** Actual values are contained within quotes

**SEGMENT DTM - DATE/TIME REFERENCE**

**PURPOSE**

To specify pertinent dates and times.

**EDI STANDARD SEGMENT**

DTM \* 374 373 \* 337 \* 623 \* 624 ~

**HSN SUBSET OF EDI STANDARD SEGMENT**

DTM \* 374 \* 373 ~

ELEMENT NUMBER	ELEMENT NAME/DESCRIPTION	ELEMENT ATTRIBUTES	COMMENTS
DTM	SEGMENT IDENTIFIER		"DTM"
374 001	<b>DATE/TIME QUALIFIER</b> Code specifying type of date or time, or both date and time.	(M ID 3/3)	" 011 "
373 002	<b>DATE</b> Date.	(C DT 8/8)	<b>HSN Mandatory</b> Shipping date (CCYYMMDD)
337 003	<b>TIME</b>	(C TM 4/8)	**NOT USED**
623 004	<b>TIME CODE</b>	(O ID 2/2)	**NOT USED**
624 005	<b>CENTURY</b>	(O NO 2/2)	**NOT USED**

**SEGMENT IT1 - BASELINE ITEM DETAIL (INVOICE)**

**PURPOSE**

To specify basic and most frequently used line item data.

**EDI STANDARD SEGMENT**

IT1	*	350	*	358	*	355	*	212	*	639	*
		235	*	234	*	235	*	234	*	235	*
		234	*	235	*	234	*	235	*	234	*
		235	*	234	*	235	*	234	*	235	*
		234	*	235	*	234	*	235	*	234	~

**HSN SUBSET OF EDI STANDARD SEGMENT**

IT1	*	350	*	358	*	355	*	212	*		
		639	*	235	*	234	*	235	*	234	~

ELEMENT NUMBER	ELEMENT NAME/DESCRIPTION	ELEMENT ATTRIBUTES	COMMENTS
IT1	<b>SEGMENT IDENTIFIER</b>		" IT1 "
350 001	<b>ASSIGNED IDENTIFICATION</b> Alphanumeric characters assigned for differentiation within a transaction set.	(O AN 1/11)	<b>HSN Mandatory</b> Invoice Line number
358 002	<b>QUANTITY ORDERED</b>	(M R 1/10)	<b>HSN Mandatory</b> Item quantity (Length ≤ 3)
355 003	<b>UNIT OF MEASUREMENT CODE</b> Code specifying the units in which a value is being expressed.	(M ID 2/2)	<b>HSN Mandatory</b> " EA "
212 004	<b>UNIT PRICE</b> Price per unit of product.	(M R 1/14)	<b>HSN Mandatory</b> Unit Price
639 005	<b>BASIS OF UNIT PRICE CODE</b> Code identifying the type of unit price for an item.	(O ID 2/2)	" NOT USED "
235 006	<b>PRODUCT/SERVICE ID QUALIFIER</b> Code identifying type of descriptive number in Product ID.	(M ID 2/2)	<b>HSN Mandatory</b> " VA " or " UP " (Vendor's Style Number or UPC code)

**NOTE REGARDING THE COMMENTS FIELD:** Actual values are contained within quotes

<b>234 007</b>	<b>PRODUCT/SERVICE ID</b> Identifying number for a product or service.	(M AN 1/30)	<b>HSN Mandatory</b> Vendor item number.
<b>235 008</b>	<b>PRODUCT/SERVICE ID QUALIFIER</b> Code identifying type of descriptive number in Product ID.	(O ID 2/2)	" IT " (HSN style number qualifier)
<b>234 009</b>	<b>PRODUCT/SERVICE ID</b> Identifying number for a product..	(O AN 1/30)	HSN's Item number (Length = 15 maximum)
<b>235 010</b>	<b>PRODUCT/SERVICE ID QUALIFIER</b>	(O ID 2/2)	**NOT USED**
<b>234 011</b>	<b>PRODUCT/SERVICE ID</b>	(C AN 1/30)	**NOT USED**
<b>235 012</b>	<b>PRODUCT/SERVICE ID QUALIFIER</b>	(C ID 2/2)	**NOT USED**
<b>234 013</b>	<b>PRODUCT/SERVICE ID</b>	(C AN 1/30)	**NOT USED**
<b>235 014</b>	<b>PRODUCT/SERVICE ID QUALIFIER</b>	(O ID 2/2)	**NOT USED**
<b>234 015</b>	<b>PRODUCT/SERVICE ID</b>	(C AN 1/30)	**NOT USED**
<b>235 016</b>	<b>PRODUCT/SERVICE ID QUALIFIER</b>	(O ID 2/2)	**NOT USED**
<b>234 017</b>	<b>PRODUCT/SERVICE ID</b>	(C AN 1/30)	**NOT USED**
<b>235 018</b>	<b>PRODUCT/SERVICE ID QUALIFIER</b>	(O ID 2/2)	**NOT USED**
<b>234 019</b>	<b>PRODUCT/SERVICE ID</b>	(C AN 1/30)	**NOT USED**
<b>235 020</b>	<b>PRODUCT/SERVICE ID QUALIFIER</b>	(O ID 2/2)	**NOT USED**
<b>234 021</b>	<b>PRODUCT/SERVICE ID</b>	(C AN 1/30)	**NOT USED**
<b>235 022</b>	<b>PRODUCT/SERVICE ID QUALIFIER</b>	(O ID 2/2)	**NOT USED**
<b>234 023</b>	<b>PRODUCT/SERVICE ID</b>	(C AN 1/30)	**NOT USED**
<b>235 024</b>	<b>PRODUCT/SERVICE ID QUALIFIER</b>	(O ID 2/2)	**NOT USED**



---

<b>234</b>	<b>PRODUCT/SERVICE ID</b>	(C AN 1/30)	<b>**NOT USED**</b>
<b>025</b>			

**SEGMENT PID - PRODUCT/ITEM DESCRIPTION**

**PURPOSE**

To describe a product or process in coded or free form format.

**EDI STANDARD SEGMENT**

PID \* 349 \* 750 \* 559 \* 751 \* 352 \*  
752 \* 822 \* 1073 ~

**HSN SUBSET OF EDI STANDARD SEGMENT**

PID \* 349 \* \* \* \* 352 ~

ELEMENT NUMBER	ELEMENT NAME/DESCRIPTION	ELEMENT ATTRIBUTES	COMMENTS
PID	SEGMENT IDENTIFIER		"PID"
349 001	ITEM DESCRIPTION TYPE Code indicating the format of a description.	(M ID 1/1)	HSN Mandatory " F "
750 002	PRODUCT/PROCESS CHARACTERISTIC CODE	(O ID 2/3)	**NOT USED**
559 003	AGENCY QUALIFIER CODE	(C ID 2/2)	**NOT USED**
751 004	PRODUCT DESCRIPTION CODE	(C AN 1/12)	**NOT USED**
352 005	DESCRIPTION A free form description to clarify the related data elements and their content.	(C AN 1/80)	HSN Mandatory Item description (Max length = 40)
752 006	SURFACE/LAYER/POSITION CODE	(O ID 2/2)	**NOT USED**
822 007	SOURCE SUBQUALIFIER	(O AN 1/15)	**NOT USED**
1073 008	YES/NO CONDITION OR RESPONSE CODE	(O ID 1/1)	**NOT USED**

**SEGMENT REF – REFERENCE NUMBERS**

**PURPOSE**

To specify identifying numbers.

**EDI STANDARD SEGMENT**

REF \* 128 \* 127 \* 352 ~

**HSN SUBSET OF EDI STANDARD SEGMENT**

REF \* 128 \* 127 ~

ELEMENT NUMBER	ELEMENT NAME/DESCRIPTION	ELEMENT ATTRIBUTES	COMMENTS
REF	SEGMENT IDENTIFIER		" REF "
128 001	REFERENCE NUMBER QUALIFIER Code qualifying the Reference Number.	(M ID 2/2)	" BV " Purchase Order Line Item Identifier
127 002	REFERENCE NUMBER Code identifying the agency assigning the code values.	(M ID 1/30)	Line number from original HSN Purchase Order
352 003	DESCRIPTION	(C AN 1/80)	***NOT USED**

**SEGMENT TDS – TOTAL MONETARY VALUE SUMMARY**

**PURPOSE**

To specify the total invoice discounts and amounts.

**EDI STANDARD SEGMENT**

TDS \* 361 \* 390 \* 391 \* 362 ~

**HSN SUBSET OF EDI STANDARD SEGMENT**

TDS \* 361 \* 390 \* 391 \* 362 ~

ELEMENT NUMBER	ELEMENT NAME/DESCRIPTION	ELEMENT ATTRIBUTES	COMMENTS
TDS	SEGMENT IDENTIFIER		"TDS"
610 001	<b>TOTAL INVOICE AMOUNT</b> Amount of invoice (including charges, less allowances) before terms discount.	(M N2 1/15)	Total amount of invoice
610 002	<b>AMOUNT SUBJECT TO TERMS DISCOUNT</b> Amount upon which the terms discount amount/percent is calculated.	(C N2 1/15)	Amount on which the discount is applied
610 003	<b>DISCOUNTED AMOUNT DUE</b> Amount of invoice due if paid by terms discount due date.	(O N2 1/15)	Total invoice less discount
610 004	<b>TERMS DISCOUNT AMOUNT</b> Total amount of terms discount.	(O N2 1/15)	Discount amount

**SEGMENT CAD – CARRIER DETAIL**

**PURPOSE**

To identify to whom administrative communications should be directed.

**EDI STANDARD SEGMENT**

CAD	*	91	*	206	*	207	*	140	*
		387	*	368	*	128	*	127	*
		284	~						

**HSN SUBSET OF EDI STANDARD SEGMENT**

CAD	*	91	*	*	*	*	387	~
-----	---	----	---	---	---	---	-----	---

ELEMENT NUMBER	ELEMENT NAME/DESCRIPTION	ELEMENT ATTRIBUTES	COMMENTS
CAD	SEGMENT IDENTIFIER		"CAD"
91 001	TRANSPORTATION METHOD/TYPE CODE Code specifying the method or type of transportation for the shipment.	(M ID 2/2)	"L"
206 002	EQUIPMENT INITIAL	(O AN 1/35)	**NOT USED**
207 003	EQUIPMENT NUMBER	(O AN 1/10)	**NOT USED**
140 004	STANDARD CARRIER ALPHA CODE	(O ID 1/2)	**NOT USED**
387 005	ROUTING Free-form description of the carrier's identity	(C AN 1/35)	Name of carrier used
368 006	SHIPMENT/ORDER STATUS CODE	(O ID 2/2)	**NOT USED**
128 007	REFERENCE NUMBER QUALIFIER	(O ID 2/3)	**NOT USED**
127 008	REFERENCE NUMBER	(C AN 1/30)	**NOT USED**
284 009	SERVICE LEVEL CODE	(O ID 2/2)	**NOT USED**

**SEGMENT SAC - ALLOWANCE, CHARGE, OR SERVICE**

**PURPOSE**

To specify allowances, charges or services.

**EDI STANDARD SEGMENT**

SAC	*	248	*	1300	*	559	*	1301	*	610	*
		378	*	332	*	118	*	355	*	380	*
		380	*	331	*	127	*	770	*	352	~

**HSN SUBSET OF EDI STANDARD SEGMENT**

SAC	*	248	*	1300	*	*	*	610	*	*	*	*	*	*	*
	*	331	*	*	*	352	~								

ELEMENT NUMBER	ELEMENT NAME/DESCRIPTION	ELEMENT ATTRIBUTES	COMMENTS
SAC	<b>SEGMENT IDENTIFIER</b>		"SAC"
248 001	<b>ALLOWANCE/CHARGE INDICATOR</b> Code which indicates an allowance or charge for the service specified.	(M ID 1/1)	<b>HSN</b> " C "
1300 002	<b>SERVICE,PROMOTION,ALLOW CHARGE CODE</b>	(C ID 2/2)	<b>HSN</b> "D240" = Freight Charge
559 003	<b>AGENCY QUALIFIER CODE</b>	(C ID 2/10)	**NOT USED**
1301 004	<b>AGENCY SERVICE, PROMOTION, ALLOWANCE, or CHARGE CODE</b> Code indicating method of handling for an allowance or charge.	(C AN 2/2)	**NOT USED**
610 005	<b>ALLOWANCE/CHARGE TOTAL AMOUNT</b> Total dollar amount for the allowance or charge.	(O N2 1/16)	<b>HSN</b> Total of charges (2 decimals implied)
378 006	<b>ALLOWANCE/CHARGE PERCENT QUALIFIER</b>	(C ID 1/1)	**NOT USED**
332 007	<b>PERCENT</b>	(C R 1/6)	
118 008	<b>RATE</b>	(O R 1/9)	**NOT USED**
355 009	<b>UOM CODE</b>	(C ID 2/2)	**NOT USED**

**NOTE REGARDING THE COMMENTS FIELD:** Actual values are contained within quotes

<b>380 010</b>	<b>QUANTITY</b>	(O R 1/10)	**NOT USED**
<b>380 011</b>	<b>QUANTITY</b>	(O R 1/10)	**NOT USED**
<b>380 012</b>	<b>ALLOWANCE/CHARGE METHOD OF HANDLING CODE</b> Code indicating method of handling for an allowance or charge.	(M ID 2/2)	<b>HSN</b> " 06 " (Charge to be paid by customer)
<b>127 013</b>	<b>REFERENCE IDENTIFICATION</b>	(C AN 1/30)	**NOT USED**
<b>770 014</b>	<b>OPTION NUMBER</b>	(O AN 1/20)	**NOT USED**
<b>352 015</b>	<b>DESCRIPTION</b> Free form description to clarify the related data elements and their content.	(C AN 1/80)	"FREIGHT"

**SEGMENT CTT - TRANSACTION TOTALS**

**PURPOSE**

To transmit a hash total for a specific element in the transaction set.

**EDI STANDARD SEGMENT**

CTT \* 354 \* 347 \* 81 \*  
355 \* 183 \* 355 \* 352 ~

**HSN SUBSET OF EDI STANDARD SEGMENT**

CTT \* 354 \* 347 ~

ELEMENT NUMBER	ELEMENT NAME/DESCRIPTION	ELEMENT ATTRIBUTES	COMMENTS
CTT	SEGMENT IDENTIFIER		"CTT"
354 001	<b>NUMBER OF LINE ITEMS</b> Total number of line items in the transaction set.	(M NO 1/6)	Total number of line items in the transaction.
347 002	<b>HASH TOTAL</b>	(O R 1/10)	**NOT USED**
81 003	<b>WEIGHT</b>	(C R 1/10)	**NOT USED**
355 004	<b>UNIT OF MEASUREMENT CODE</b>	(C ID 2/2)	**NOT USED**
183 005	<b>VOLUME</b>	(C R 1/8)	**NOT USED**
355 006	<b>UNIT OF MEASUREMENT CODE</b>	(C ID 2/2)	**NOT USED**
352 007	<b>DESCRIPTION</b>	(O AN 1/80)	**NOT USED**



---

**SEGMENT SE - TRANSACTION SET TRAILER**

**PURPOSE**

To indicate the end of the transaction set and provide the count of the transmitted segments (including the beginning (ST) and the ending (SE) segments).

**EDI STANDARD SEGMENT**

SE \* 96 \* 329 ~

**HSN SUBSET OF EDI STANDARD SEGMENT**

Same as the EDI Standard Segment.

	<b>ELEMENT NAME/DESCRIPTION</b>	<b>ELEMENT ATTRIBUTES</b>	<b>COMMENTS</b>
<b>SE</b>	<b>SEGMENT IDENTIFIER</b>		"SE"
<b>96 001</b>	<b>NUMBER OF INCLUDED SEGMENTS</b> Total number of segments included in a transaction set including ST and SE segments.	(M N0 1/10)	Total number of segments
<b>329 002</b>	<b>TRANSACTION SET CONTROL NUMBER</b> Identifying control number that must be unique within the transaction set functional group assigned by the originator for a transaction set.	(M AN 4/9)	Suppliers sequential number

---

**SEGMENT GE - FUNCTIONAL GROUP TRAILER**

**PURPOSE**

To indicate the end of a functional group and to provide control.

**EDI STANDARD SEGMENT**

GE \* 97 \* 28 ~

**HSN SUBSET OF EDI STANDARD SEGMENT**

Same as EDI Standard Segment

	<b>ELEMENT NAME/DESCRIPTION</b>	<b>ELEMENT ATTRIBUTES</b>	<b>COMMENTS</b>
<b>GE</b>	<b>SEGMENT IDENTIFIER</b>		" GE "
<b>97 001</b>	<b>NUMBER OF TRANSACTION SETS INCLUDED.</b> Count of ST segments within the Group.	(M NO 1/6)	Total number of transaction sets included in the GS - GE group.
<b>28 002</b>	<b>GROUP CONTROL NUMBER</b> Assigned number originated and maintained by the sender.	(M NO 1/9)	Same number as in GS segment (data element 06)

---

**SEGMENT IEA - INTERCHANGE CONTROL TRAILER**

**PURPOSE**

To define the end of an interchange of one or more functional groups and interchange-related control segments.

**EDI STANDARD SEGMENT**

IEA \* I16 \* I12 ~

**HSN SUBSET OF EDI STANDARD SEGMENT**

Same as EDI Standard Segment.

	<b>ELEMENT NAME/DESCRIPTION</b>	<b>ELEMENT ATTRIBUTES</b>	<b>COMMENTS</b>
<b>IEA</b>	<b>SEGMENT IDENTIFIER</b>		" IEA "
<b>I16 001</b>	<b>NUMBER OF INCLUDED FUNCTIONAL GROUPS</b> A count of the number of included groups included in a transmission.	(M N0 1/5)	Count of the GS segments in the transmission.
<b>I12 002</b>	<b>INTERCHANGE CONTROL NUMBER</b> Number that uniquely identifies the interchange data. It is assigned by the sender.	(M N0 9/9)	Same number as in the ISA segment (data element 13)

### TRANSACTION LAYOUT

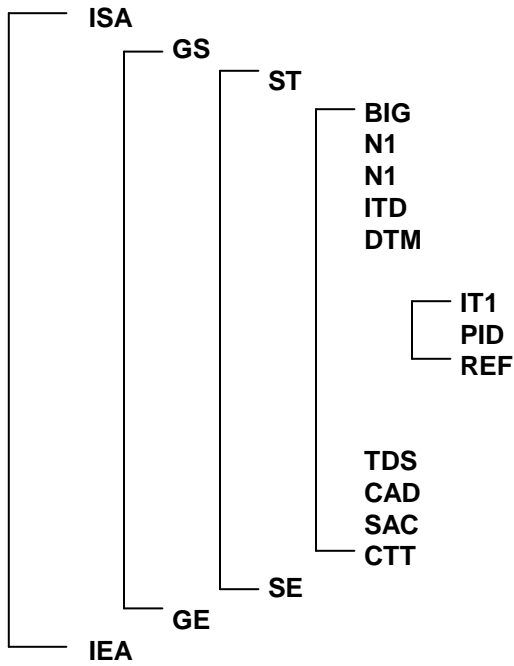

Home Shopping Network  
Transaction Set 810

01/17/10  
Page 29

---

Example Transaction Set:

ISA\*00\*                   \*00\*                   \*01\*999920703A           \*12\*8135728585  
\*000510\*0803\*U\*00401\*000001124\*0\*P\*>  
GS\*IN\*999920703A\*8135728585\*20000510\*0803\*1134\*X\*004010  
ST\*810\*11340001  
BIG\*20000509\*5331542\*20000509\*697840\*\*\*DI  
N1\*ST\*SALEM\*92\*99  
N1\*SU\*CLEAN CORPORATION\*92\*091774  
ITD\*ZZ\*2\*\*\*\*20000608\*30  
DTM\*011\*20000509  
IT1\*1\*342\*EA\*40.68\*\*VA\*HBS1542184\*IT\*284075  
PID\*F\*\*\*\*3MM ALLOY HERRINGBONEHAIN  
REF\*BV\*001  
IT1\*2\*219\*EA\*41.35\*\*VA\*HBS2309204\*IT\*229479  
PID\*F\*\*\*\*026 HERRINGBONENGBONEHAIN  
REF\*BV\*002  
IT1\*3\*362\*EA\*52.05\*\*VA\*HBS1542244\*IT\*284078  
PID\*F\*\*\*\*3MM ALLOY HERRINGBONEHAIN  
REF\*BV\*003  
IT1\*4\*312\*EA\*20.85\*\*VA\*SIN1430204\*IT\*284082702  
PID\*F\*\*\*\*SINGAPORE CHAIN W/ALLOYIN  
REF\*BV\*004  
IT1\*5\*77\*EA\*22.67\*\*VA\*SIN1430224\*IT\*284081702  
PID\*F\*\*\*\*SINGAPORE CHAIN W/ALLOYIN  
REF\*BV\*005  
TDS\*5006110\*5006110  
CAD\*L\*\*\*\*FEDERAL EXPRESS  
CTT\*5  
SE\*25\*11340001  
GE\*1\*1134  
IEA\*1\*000001124